

KBM 38 X

Magnetic Core Drilling Machine

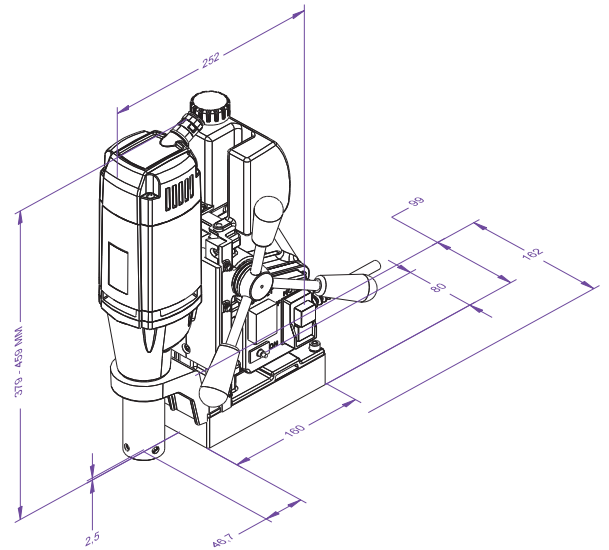

Use :

- Electrical installation, sanitary and heating installations
- Civil engineering, industrialised building construction

Features:

- Line lockout
- Safety Belt
- Carrying Case
- Powerful motor
- Superb service life
- Extremely lightweight
- Powerful electromagnet
- Epoxy sealed waterproof base
- Internal spindle cooling system
- Safety fuse protection for magnet
- Over load protection switch

Specification	KBM 38 X
Rated Voltage (V) :	220-240
Power Input (W) :	900
Core Cutting Capacity (mm)	12 to 38
Core Cutting Depth (mm)	50
Rated Speed (RPM)	400
Weight (kg)	9.5
Direct Arbour (mm)	19 weldon

* Core Bit is not a part of standard accessory