

Magnetic Core Drilling

# KBM 35 X

Magnetic Core Drilling Machine



**EIBENSTOCK  
POSITRON**

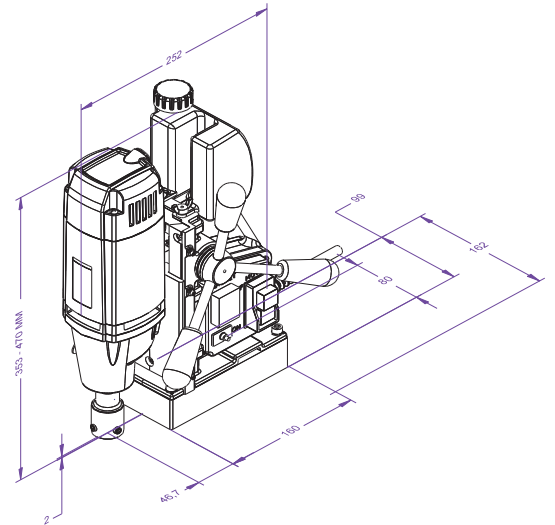

### Use :

- Electrical installation, sanitary and heating installations
- Civil engineering, industrialised building construction

### Features:

- Line lockout
- Safety Belt
- Carrying Case
- Powerful motor
- Superb service life
- Extremely lightweight
- Powerful electromagnet
- Epoxy sealed waterproof base
- Internal spindle cooling system
- Safety fuse protection for magnet
- Over load protection switch

Specification	KBM 35 X
Rated Voltage (V) :	220-240
Power Input (W) :	900
Core Cutting Capacity (mm)	12 to 35
Core Cutting Depth (mm)	50
Rated Speed (RPM)	400
Weight (kg)	8
Direct Arbour (mm)	19 weldon

\* Core Bit is not a part of standard accessory

Eibenstock Positron Elektrowerk Pvt. Ltd.  
Plot No. 144/1,2,3, KATP, Tardal,  
Taluka- Hatkanangale,  
Dist. Kolhapur – 416 121,  
Maharashtra, (INDIA)

GERMAN ENGINEERING

मेड इन इंडिया

[www.eibenstock.in](http://www.eibenstock.in)  
[www.facebook.com/EibenstockPositron](https://www.facebook.com/EibenstockPositron)

A partner  
company of  
The German  
Power Tool  
Manufacturer



**EIBENSTOCK  
Power Tools**