

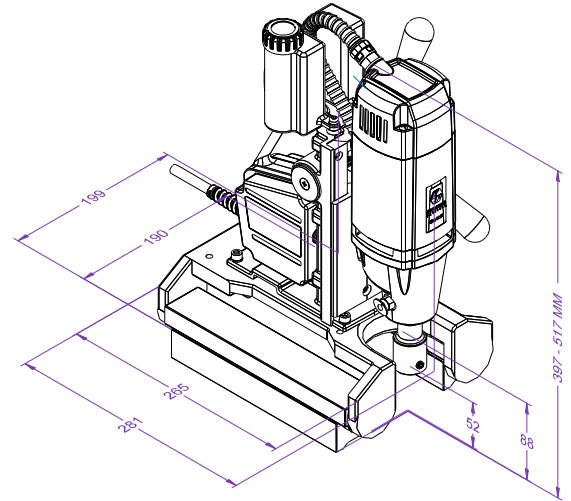

PDM 35 X

PERMANENT MAGNETIC PIPE CORE DRILLING MACHINE

EIBENSTOCK
P O S I T R O N



Use :

- Sanitary And Heating Installation and All Pipe Industry.
- Civil engineering, Industrialised building construction.

Features:-

- Line Lockout
- Safety Belt
- Carry Case
- Powerful motor
- Superb service life
- Extremely Light weight
- Two self levelling Powerful Permanent Magnet
- Internal spindle cooling system
- Over load protection switch

* Core Bit is not a part of standard accessory

SPECIFICATION	PDM 35 X
RATED VOLTAGE (V) :	220-240
POWER INPUT (W) :	900
RATED SPEED (RPM)	400
CORE CUTTING CAPACITY (mm)	12 to 35
Direct Arbour (mm)	19 Weldon
Minimum Pipe size (mm)	100
Maximum pipe size (mm)	500
Maximum Thickness of pipe (mm)	13
Minimum Square pipe size (mm)	90
WEIGHT (Kg.)	13.45

Eibenstock Positron Elektrowerk Pvt. Ltd.
Plot No. 144/1,2,3, KATP, Tardal,
Taluka- Hatkanangale,
Dist. Kolhapur – 416 121,
Maharashtra, (INDIA)

GERMAN ENGINEERING

मेड इन इंडिया

www.ep-india.in

www.facebook.com/EibenstockPositron

A partner
company of
The German
Power Tool
Manufacturer



EIBENSTOCK
Power Tools