

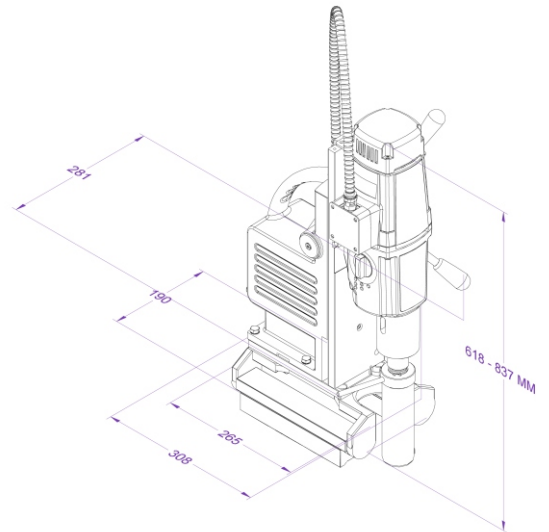

PDM 85-3 X

MAGNETIC PIPE CORE DRILLING MACHINE

**EIBENSTOCK
POSITRON**



Use:

- Electrical installation, sanitary and heating installations
- Civil engineering, industrialised building construction & Heavy fabrication
- Specially for Piping

Features:

- Mechanical safety clutch
- Feed lever change without any tools – easy change of the working site
- Line lock out
- Safety Belt
- Powerful motor
- Superb service life
- Internal cable arrangement
- 100% high tensile alien headed screws
- Compact, Light weight core drill

Specification	PDM 85-3 X
OVERALL SIZE	308(L)x281(B)x(618-837)(H)
WEIGHT	28 Kg.
MAGNET SIZE	265(L)x190.5(W)x88.5(H)
MINIMUM PIPE SIZE	100 MM
RATED SPEED	110/190/280 RPM
VOLTAGE	230 V
MIN.SQUARE PIPE SIZE	90 MM.
SPINDLE TYPE	32 MM WELDON MT3 SLEEVE
CORE CUTTING CAPACITY	60 MM
TWIST DRILL SIZE	55 MM

* Core Bit is not a part of standard accessory

Eibenstock Positron Elektrowerk Pvt. Ltd.
Plot No. 144/1,2,3, KATP, Tardal,
Taluka- Hatkanangale,
Dist. Kolhapur – 416 121,
Maharashtra, (INDIA)

GERMAN ENGINEERING

मेड इन इंडिया

www.eibenstock.in
www.facebook.com/EibenstockPositron

A partner
company of
The German
Power Tool
Manufacturer



**EIBENSTOCK
Power Tools**