

KBM 42 I

Magnetic Core Drilling Machine

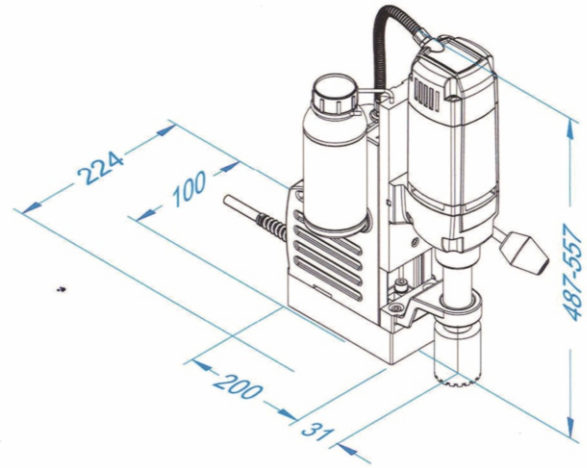

Use :

- ➔ Electrical installation, sanitary and heating installations
- ➔ Civil engineering, industrialised building construction

Features :

- ➔ Line lock out
- ➔ safety Belt
- ➔ Powerful motor
- ➔ Superb service life
- ➔ Powerful electromagnet
- ➔ Epoxy sealed waterproof base
- ➔ Internal spindle cooling system
- ➔ Safety fuse protection for magnet
- ➔ 100% high tensile alien headed screws
- ➔ Unmistaken arrangement of switch for magnet & drill to ensure safety of operator
- ➔ Core Bits - Optional accessory as per your requirement. 1150.

• Available in 110V on special request

Specification	KBM 42
Input Supply Voltage (V)	220 - 240
Motor Input (W)	115
Core Cutting Capacity (mm)	12 to 50
Core Cutting Depth (mm)	50
Rated Speed (RPM)	450/250
Weight (Kg)	12.5
Twist Drill Capacity (mm)	22

* Core Bit is not a part of standard accessory