

## PDB 200

### Diamond Core Drill Machine

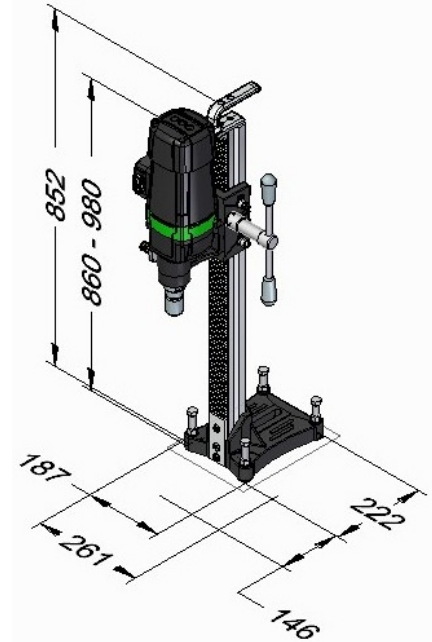

#### Use :

- Wet drilling in reinforced concrete, natural stone and asphalt.
- Sanitary, heating and ventilation construction, other engineers, civil engineering, landscape construction.

#### Features :

- Switch with over current cut-off - protection against overloading of the motor
- Cutt-off carbon brushes - protection of the motor
- 1-speed oil bath gearbox - optimal lubrication
- Mechanical safety clutch
- Integrated water supply
- Stainless steel-combination spindle for connecting to R $\frac{1}{2}$ " and 1 $\frac{1}{4}$ " drill bits
- Motor and rig as a complete unit
- Handy, robust and economical
- Space-saving, compact drilling unit - low weight

Specification	PDB 200
Input Supply Voltage (V)	220-240
Motor Input (W)	2500
Core CuttingCapacity (mm)	200
Stroke (mm)	490
Rated speed(RPM)	450
Mechanical Safety Clutch	Available
Spindle Connection	1 1/4" UNC
Weight (kg)	14 Kg