

WBM 40

Magnetic Core Drilling Machine

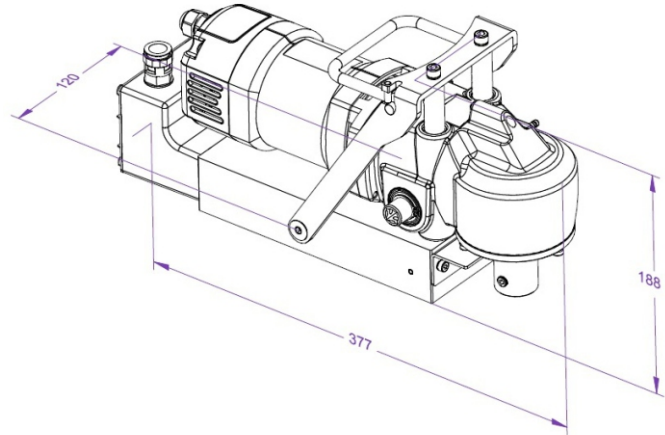

Core Bits



Standard Accessories

Use :

- ➔ Electrical installation, sanitary and heating installations, Vehicle Construction.
- ➔ Civil engineering, industrialised building construction & Heavy fabrication

Features :

- ➔ Easy Feed lever change
- ➔ Line lock out
- ➔ Safety Belt
- ➔ Powerful motor
- ➔ Superb service life
- ➔ Powerful electromagnet
- ➔ Epoxy sealed waterproof base
- ➔ Internal spindle cooling system
- ➔ 100% high tensile alien headed screws
- ➔ Un-mistaken arrangement of switch for magnet & drill to ensure safety of operator
- ➔ Pipe Clamping Attachment & Core Bits are Optional accessory as per your requirement

Speciafication	WBM 40
Input Supply Voltage (V)	220 - 240
Motor Input (W)	1300
Max Core Cutting Capacity (mm)	12 - 40
Max Core Cutting Depth (mm)	25
Rated Speed (RPM)	320
Weight (Kg)	12.1

*** Pipe Clamping Attachment & Core Bit in not a part of standard accessory**