



**Big cutting depth up to 130 mm**



**ETR 350 P: Integrated water supply with flow regulator**  
easy adjustment of the water-volume



**Ø 350**

**Special developed suction system for dust reduced working**

SPECIFICATIONS	ETR 350/ETR 350 P
Power input	2700 W
Rated voltage	230 V ~
Rated speed	2200 rpm
Max. disc diameter	350 mm
Max. cutting depth	130 mm
Spindle connection	Ø 25.4 mm
Weight	12.5 kg/12.9 kg
Order no.	06815000/06818000

Supplied

in a box incl. diamond cutting disc Ø 350 mm, dust guard and assembly tools

**Cutting systems**  
**ETR 350 (dry)/ETR 350 P (wet/dry)**

**The powerful cutting systems for dust reduced cutting**

**USE:**

- Cutting of mineral materials, f. e. concrete, brick and natural stone
- Breakthroughs into brickwork
- Wall cuttings for installations
- Slitting of expansion joints
- Civil engineering, drilling and sawing operators, garden and landscaping trade

**FEATURES:**

- Special oil bath gearbox with optimal adjusted speed for fast working
- Best results in system with the EE premium diamond cutting disc
- Immersion function
- Adjustable cutting depth limitation without any tools f. e. for the cutting of screed (accessory)
- Adapter and diamond cutting disc for working near to the edge (accessory)
- Exact wall cuttings by using a guide rail (accessory) – easy mounting, easy feed, low vibration
- Wide supporting rolls – exact guiding
- Spindle lock – easy tool change
- Robust metal suction hood
- Handle and hood adjustable – ergonomic handling in different working positions
- Nozzle diameter 35 mm – direct connection of industrial vacuum cleaner of EIBENSTOCK DSS series
- Electronic – soft start, constant speed, temperature control and over current cut-off, overload indication
- Cut-off carbon brushes – protection of the motor



precise cutting depth adjustment (accessory)



working near to the edge with accessory set + diamond cutting disc (accessory)



## SYSTEM OF GUIDE RAILS AS ACCESSORY

**Safe, precise and energy-saving –  
System of Guide rails with crank feed  
for relaxed working**



**Quick mounting  
Easy transport by only person  
Robust carriage mounted on roller  
bearings – easy feed**

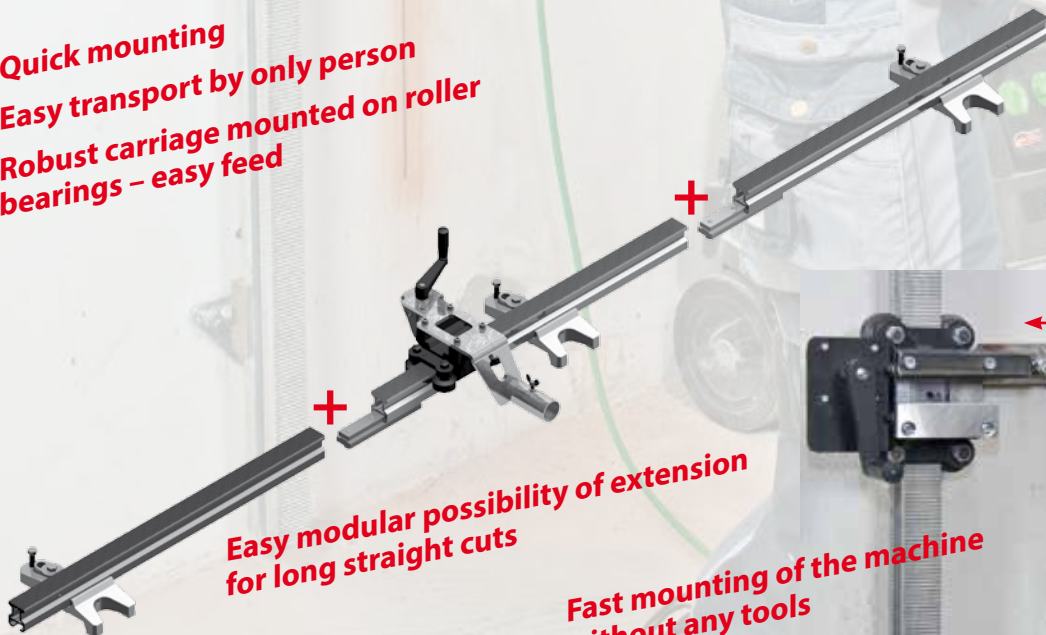















**Easy modular possibility of extension  
for long straight cuts**

**Fast mounting of the machine  
without any tools**





## Sawing/Cutting/Slitting ACCESSORIES

FOR CUTTING AND GRINDING SYSTEMS			
	15	Diamond cutting disc Ø 230 mm	37448000
	16	Diamond cutting disc Premium, Ø 350 mm	3744G000
	17	Diamond cutting disc near to the edge Premium, Ø 350 mm	3744H000
	18	Set of Adapter for cutting near to the edge for ETR 350/ETR 350 P	3744K000
	19	Adjustment and limitation for cutting depth incl. cover plate for ETR 350/ETR 350 P	3744L000
	20	Set of Guide rails 200 cm for ETR 350/ETR 350 P 2x Guide rail 100 cm incl. machine holder, connection and mounting	3744N000
	21	Guide rail 100 cm for ETR 350/ETR 350 P incl. connection and mounting	3744P000
	22	Fastening set for Guide rails for ETR 350/ETR 350 P	35729000
FOR DOUBLE BLADE SWORD SAW			
	23	Blade set Universal Premium, 2 parts	37452000
FOR WALL CHASERS			
	24	Diamond blade Premium Ø 125 mm	3744D000
	25	Diamond blade Standard Ø 150 mm	37440000
	26	Diamond blade Premium Ø 150 mm	37441000
	27	Diamond blade Premium Ø 180 mm	37443000
	28	Distance disks for EMF 150.1/EMF 180 for the using of 3 blades	3744E000
	29	for the using of 4 blades	3744S000