

KBM 42 I

Magnetic Core Drilling Machine

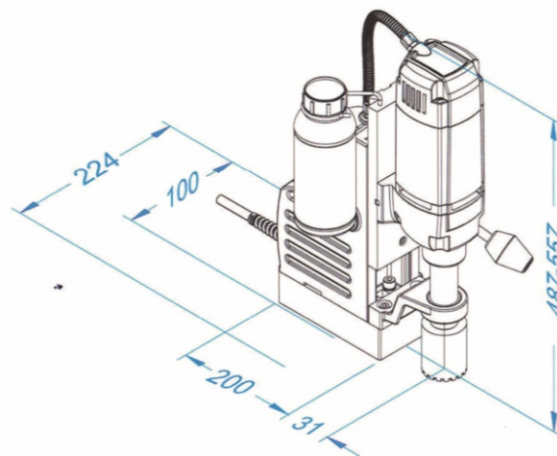

Use :

- Electrical installation, sanitary and heating installations
- Civil engineering, industrialised building construction

Features :

- Line lock out
- safety Belt
- Powerful motor
- Superb service life
- Powerful electromagnet
- Epoxy sealed waterproof base
- Internal spindle cooling system
- Safety fuse protection for magnet
- 100% high tensile alien headed screws
- Unmistaken arrangement of switch for magnet & drill to ensure safety of operator
- Core Bits - Optional accessory as per your requirement. 1150.

● Available in 110V on special request

Specification	KBM 42 I
Input Supply Voltage (V)	220 - 240
Motor Input (W)	1200
Core Cutting Capacity (mm)	12 to 50
Core Cutting Depth (mm)	50
Rated Speed (RPM)	450/250
Weight (Kg)	12.5
Twist Drill Capacity (mm)	22

* Core Bit is not a part of standard accessory