

# KBM 42 R-RL

Magnetic Core Drilling Machine

**EIBENSTOCK**  
P O S I T R O N

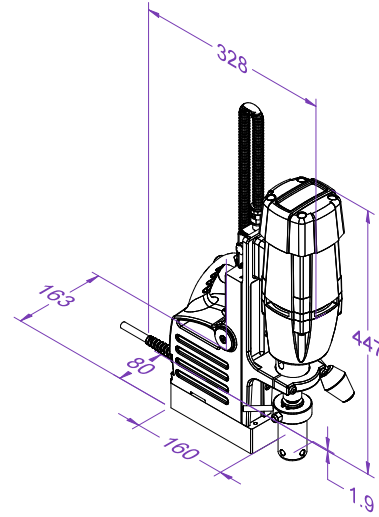

**Use:**

- Electrical installation, sanitary and heating installations
- Civil engineering, industrialised building construction

**Features:**

- Line lock out
- Safety Belt
- Powerful motor
- Superb service life
- Powerful electromagnet
- Epoxy sealed waterproof base
- Internal spindle cooling system
- Safety fuse protection for magnet
- 100% high tensile alien headed screws
- Unmistaken arrangement of switch for magnet & drill to ensure safety of operator
- Core Bits - Optional accessory as per your requirement.



\* Core Bit is not a part of standard accessory

Specification	KBM 42 R - RL
Input Supply Voltage (V)	220 - 240
Motor Input (W)	1200
Core Cutting Capacity (mm)	12 to 50
Core Cutting Depth (mm)	50
Rated Speed (RPM)	100-250/180-450
Weight (kg)	12.7
Twist Drill Capacity (mm)	22
Tapping	M12