

KBM 42-2

Magnetic Core Drilling Machine

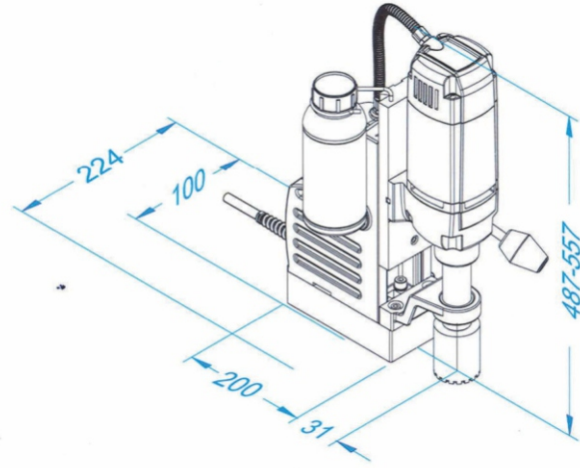

Use :

- ➔ Electrical installation, sanitary and heating installations,
- ➔ Civil engineering, industrialised building construction

• Available in 110V on special request

Features :

- ➔ Line lock out
- ➔ Safety Belt
- ➔ Powerful motor
- ➔ Superb service life
- ➔ Powerful electromagnet
- ➔ Epoxy sealed waterproof base
- ➔ Internal spindle cooling system
- ➔ Safety fuse protection for magnet
- ➔ 100% high tensile alien headed screws
- ➔ Un-mistaken arrangement of switch for magnet & drill to ensure safety of operator
- ➔ Core-Bits - Optional accessory as per your requirement

Speciafication	KBM 42 - 2
Input Supply Voltage (V)	220 - 240
Motor Input (W)	1200
Core Cutting Capacity (mm)	12 to 42
Core Cutting Depth (mm)	50
Rasted Speed (RPM)	250/450
Weight (Kg)	17.5
Twist Drill Capacity (mm)	22

* Core Bit is not a part of standard accessory