

EBS 125 I

Powerful Grinder & Polysher

**EIBENSTOCK
POSITRON**

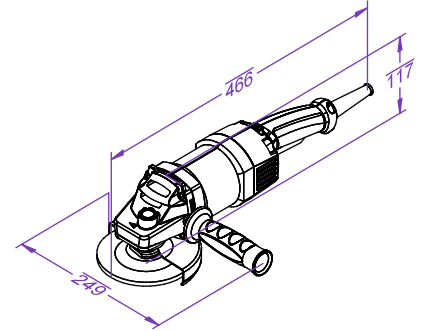

Use :

- Grinding and smoothing of surfaces
- Removing of screed seams, residual mud, plaster and coatings
- Preparing of surfaces, e.g. for tile renovation
Concrete, screed, tile adhesive, plaster, paint, coatings, carpet, adhesive - with special grinding wheels (accessories)
- Working in tight spots for example under radiators, protrusions

Features :

- Foldable front edge of dust guard for grinding directly to the edge of the work area
- Slim housing design-compact, well balanced design
- Soft grip handle - less vibration
- Spindle lock - easy tool change



VC 50

**vacuum Cleaner
Wet and dry**

Note : Vacuum cleaner VC50 is optional accessory and not part of standard scop

Specification	EBS 125 I
Input supply Voltage (V)	220 - 240
Motor input (W)	1400
Grinding Disc Diameter (mm)	125
No load Speed (min ⁻¹)	8000
Thread of Work Spindle	M14
Weight (kg)	3.2