

KBM 50P.2, DRIVE UNIT 230V

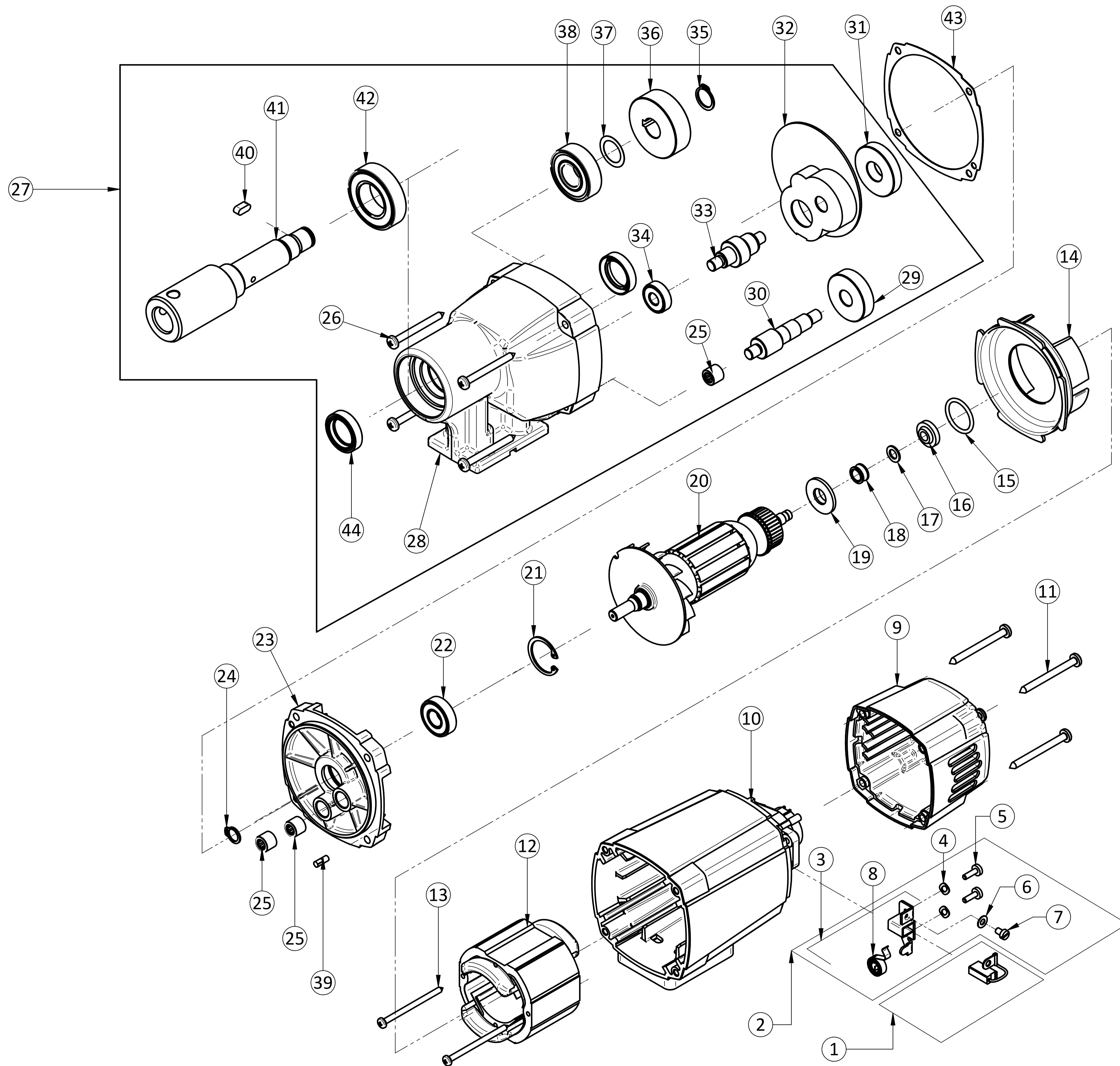

DU KBM 50P.2_230V			
Sr.No.	Part Name	Part No	Qty
1	Auto Cutoff Carbon Brush Pair	209942	1
2	Brush Holder SA total	319935	2
3	Brush Holder SA (209902)		2
4	Wave washer M4 TYPE B (421704)		4
5	CH screw M4x12 (161710100)		4
6	Star Washer M4 (211730)		2
7	CH screw M4 x 8 (101730100)		2
8	Flat spiral spring (200503)		2
9	Back cover	210420	1
10	Field Case	120407100	1
11	Phillip head self tap screw 4.8x55	311701	4
12	Field SA	7432A150	1
13	CH self tap screw 3.9x60 (80201266)	201703	2
14	Baffle	7732Y140	1
15	O ring	200303	1
16	Magnetic disc	80701005	1
17	Presspan Washer	82000951	1
18	Ball Bearing (8-22-7) 608 ZZ	110902101	1
19	Dust washer	200404	1
20	Armature SA	7432A100	1
21	Circlip 28mm x 1.2 B TYPE	201704	1
22	Ball Bearing (12-28-8)6001 ZZ	190901	1
23	GC Cover	120190100	1
24	Circlip A11	121771100	1
25	NRB 8-12-10 HK810	250901	3
26	Phillip head self tap screw 4.8x55	311701	4
27	Gear case SA	719948	1
28	Gear case (710129)		1
29	Intermediate gear2 (710255)		1
30	Inter pinion 2 (710256)		1
31	Intermediate gear (7132A470)		1
32	Grease barrier (7132A625)		1
33	Inter pinion (710254)		1
34	Ball Bearing 8-22-7 (608 ZZ) (110902101)		1
35	Circlip 15 x 1 A TYPE (121765100)		1
36	Spindle gear (71323430)		1
37	Washer 15/22 x 0.2 (311704)		1
38	Ball bearing 17-40-12 (6203-2RS)	190903	1
39	Dowel 4 x 12 (211723)		1
40	Key 5-5-12 (80200601)		1
41	Spindle (3702213)		1
42	Ball bearing (6005-2RS)(80410061)		1
43	Gasket	120307100	1
44	Oil seal 20-30-7	210302	2

PART NO. 711442	REV: D1
--------------------	------------