

PEHB 20-2.4 RL

Drilling Machine

EIBENSTOCK
POSITRON

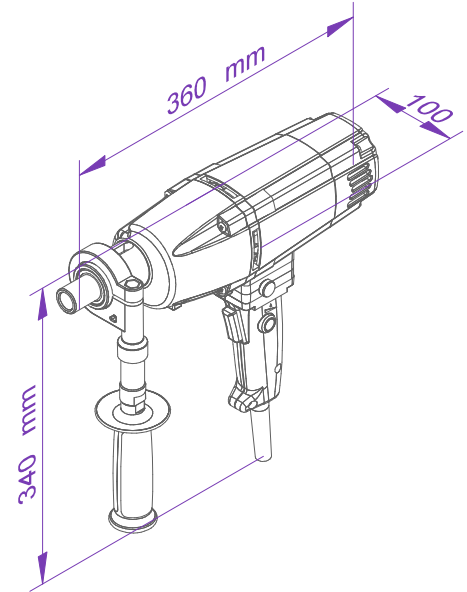

Use :

- Hand-held or stand mounted drilling in wood, aluminum, steel
- Screwing and tapping (clockwise/anticlockwise rotation and torque control)
- As a driving motor
- Metal and timber construction, machine, plant and vehicle construction
- Mobile for easy transport to site

Features:

- Adjustable handle with aluminum clamp – allows adaptation to the application and working position
- Long front handle allowing for easy handling at high torque and optimal power transmission
- Spade handle – optimal power transmission
- Soft start and thermal overload for the protection of the machine and user
- Constant speed and torque control allows for precise drilling
- Morse taper connection – versatile spindle connection

Specification	PEHB-20 2.4 RL
Input Supply Voltage (V) :	220 - 240
Motor Input (W) :	1200
Drilling Ø (mm) :	20
Rated Speed (min ⁻¹) : n	100-250 / 180-450
Spindle Connection :	MK2
Collar diameter (mm) :	46
Reverse – Forward :	Yes
Weight (kg) :	4.4 kg

* Bit is not a part of standard accessory