

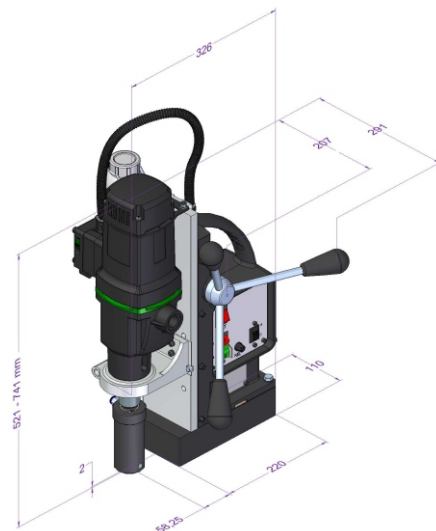

KBM 90

Magnetic Core Drilling Machine

**EIBENSTOCK
POSITRON**



Use :

- Electrical installation, sanitary and heating installations.
- Civil engineering, industrialized building construction & Heavy fabrication
As a driving motor

Features:

- Mechanical safety clutch
- Easy feed lever Change
- Line lockout
- Safety Belt
- Powerful motor
- Superb service life
- Powerful electromagnet
- Epoxy sealed waterproof base
- Internal spindle cooling system
- Safety fuse protection for magnet
- 100% high tensile alien headed screws
- Unmistaken arrangement of switch for magnet & drill to ensure safety of operator
- Soft Start and Thermal over load for the protection of the machine & user (EHB 32/2.2 R R/L)
- Constant speed and torque control allows for precise drilling (EHB 32/2.2 R R/L)
- Tapping attachment, Tapping Collet, Pipe Clamping Attachment & Core Bits are Optional accessory as per your requirement

Specification	KBM 90
Input Supply Voltage (V) :	220 - 240
Motor Input (W) :	1800
Max Core cutting capacity (mm)	100
Max Core cutting Depth (mm)	100
Rated Speed(RPM)	60-140 /200-470
Tapping Capacity(mm)	Uo to M24
Electro Torque control	Yes
Thermal Overload Protection	Yes
weight (Kg)	27.5

* Bit is not a part of standard accessory

Eibenstock Positron Elektrowerk Pvt. Ltd.
Plot No. 144/1,2,3, KATP, Tardal,
Taluka- Hatkanangale,
Dist. Kolhapur – 416 121,
Maharashtra, (INDIA)

GERMAN ENGINEERING

मेड इन इंडिया

www.ep-india.in
www.facebook.com/EibenstockPositron

A partner
company of
The German
Power Tool
Manufacturer



**EIBENSTOCK
Power Tools**